

ECOMAR SX

The Sewage Treatment Plants series, type designed as ECOMAR SX, is certified in accordance with the Resolution MEPC.227(64). The ECOMAR SX series is designed to be very compact in order to minimize the required space on board a vessel for the installation. Built to work in marine environments with extreme conditions of temperature, humidity and vibrations. Different models are available covering a wide range of capacities to better fulfill all needs of every kind of applications.

The ECOMAR SX treats batches of sewage using a special chemical-physical treatment and flocculation processes with a final post-treatment prior to overboard discharge. The ECOMAR SX series is equipped with a new automatic backwash system for Post Treatment System combined to automatic treatment cycle of backwash water that doesn't need the intervention of any operator. The ECOMAR SX series is also able to work with Sewage Vacuum Toilet Systems, available as options on request.

Easy to run with fully automatic operation, the ECOMAR SX can be controlled remotely and interfaced to the on board existing control systems.



According to the
IMO Res. MEPC.227(64).

Main ECOMAR SX features:



ON/OFF TYPE

Quick start up of the STP. No stabilization time required.



EASY TO USE

Fully automatic operation. The auto-run cycle is continuous and doesn't need the intervention of any operator.



COMPACT DESIGN

Created specifically for all marine applications with required high treatment capacity in small areas.



LIGHTEST

Small footprint. Main treatment units available in strong polypropylene to save weight.



LOW MAINTENANCE COST

Reduced maintenance cost due to low consumables request.



ECO-FRIENDLY

No replacing filters required, preserving the environment from waste products.



NO DILUTION

No dilution water required.



AUTOMATIC BACKWASH TREATMENT CYCLE

Automatic backwash system combined to an automatic treatment cycle of backwash water.



SIMPLE MAINTENANCE

Few easy and simple maintenance processes are required.



OPTIMIZED HUMAN-MACHINE INTERFACE

Systems allow an interaction with the user through an easily understandable and optimized control panel.



LOW ENERGY CONSUMPTION

High efficiency components for a low Energy consumption, suitable for every ship power supply.



CUSTOMIZABLE

Multi-tank control, different footprint, customizable skid layout, dedicated accessories and other tailor made solutions on request.



WATER RECYCLING

High sewage treatment performance allows the usage of treated water for reuse (toilet flush).



ECOMAR 20 SX



ECOMAR 32 SX



ECOMAR 45 SX



ECOMAR 70 SX



ECOMAR 145 SX



ECOMAR 230 SX



ECOMAR 340 SX



ECOMAR 545 SX

ECOMAR SX

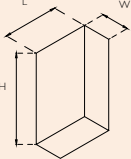
TECHNICAL SPECIFICATIONS		ECOMar 20 SX	ECOMar 32 SX	ECOMar 45 SX	ECOMar 70 SX	ECOMar 145 SX	ECOMar 230 SX	ECOMar 340 SX	ECOMar 545 SX	
Capacity (m ³ day)		3.9	5.8	7.4	10.9	19.1	36.1	53.9	84.7	
Power supply		230VAC-1Ph / 400VAC-3Ph other voltages available on request					400VAC-3Ph – other voltages available on request			
Max Power consumption (kW)		1.3	1.3	1.8	1.8	1.8	3.8	4.7	10.8	
Main components dimensions (LxWxH) (m) 	Main treatment unit	A316L config.	0.7x0.5x0.8	0.9x0.5x0.8	0.9x0.5x0.8	0.9x0.7x0.8	1.3x0.8x0.9	1.3x1.0x1.4	1.4x1.3x1.4	1.9x1.7x1.5
		PP config.	0.7x0.5x0.8	0.9x0.5x0.8	0.9x0.5x0.8	-	-	-	-	-
	Post Treatment Station	0.4x0.5x0.5	0.4x0.5x0.5	0.4x0.6x0.5	0.4x0.6x0.5	0.4x0.6x0.5	0.7x1.1x1.6	0.7x1.1x1.6	0.8x1.1x1.6	
Total weight dry (kg)	A316L configuration		146	156	237	243	253	618	618	1560
	PP configuration		132	136	174	-	-	-	-	-

Flow Diagram

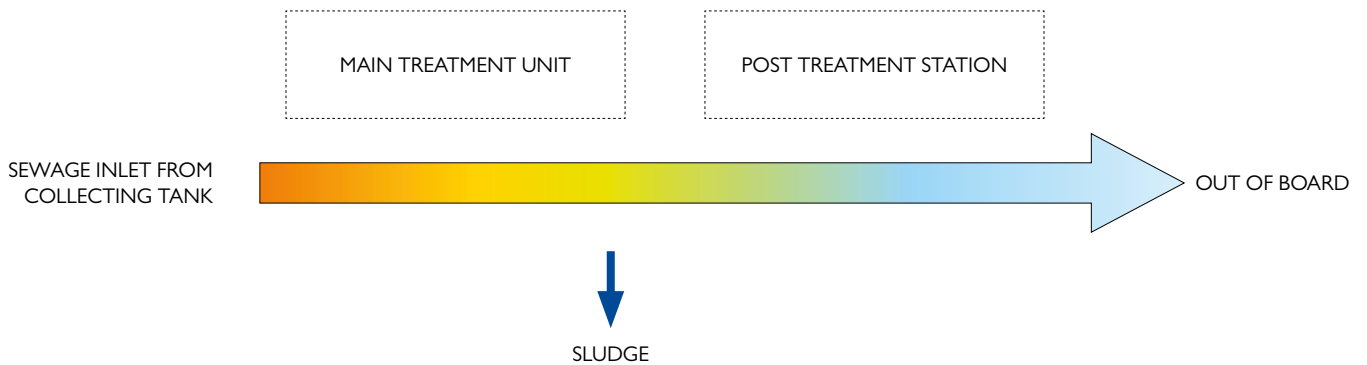

Standard modular configuration

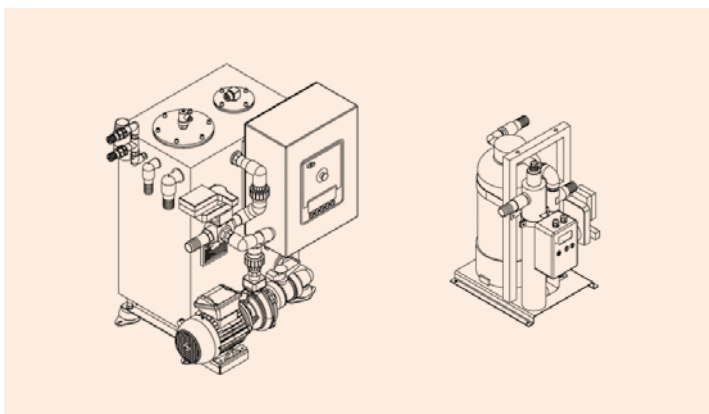

Framed configuration

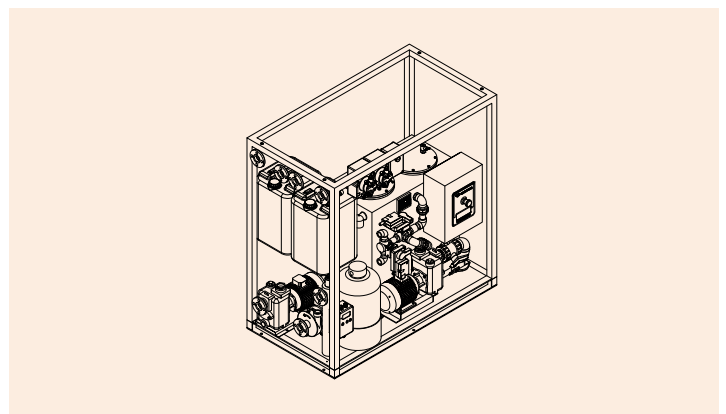

ACCESSORIES

REMOTE CONTROL DEVICES

7" LCD Touch-screen

The remote control TOUCH SCREEN, 7" size (other sizes available on request) and 65.000 colours, allows to start, stop and monitor the running/alarm system status. This remote control shows also an alarm data logger.



CDMAR-3

Remote control panel, model CDMAR-3, with touch buttons and back lighted liquid crystal display and provided with three key buttons (START/STOP/RESET). It allows to start, stop and monitor the running/alarm system status.



Modbus

Holding register Modbus protocol, RTU type, for the serial (RS-485/422) cable connection of the plant to onboard command and monitoring system.

It allows to start, stop and monitor the running/alarm system status.

OPTIONS

SLUDGE DISCHARGE PUMP

Sludge pump models available for the sludge transfer from a sludge tank to a shore connection or directly overboard according to IMO/MARPOL regulation.

Sludge Emptying System

Complete with sludge pump, control box and level sensors available on request.



MAX ABSOLUTE LEVEL SENSOR FOR SLUDGE TANK

Side mounting level sensor (LPO) for monitoring the max absolute level inside the sludge tank.



WASH WATER INLET DEVICE

As alternative to wash pump, Water inlet device for the automatic washing of both sewage treatment tank and multilevel sensor with clean (sea or fresh) water supplied from the ship water pump system (an Active Carbon filter to reduce free chlorine content from the wash water line available on request).



WATER STRAINER FILTER

Nickel-plated bronze water strainer to filter marine debris from sea wash water supply.



SEWAGE WATER TRANSFER SYSTEM

Transfer control system able to transfer from any collecting sewage (black and/or grey) water tanks to the piloted STP collecting tank, complete with Transfer System Control Box, Level Sensors and Transfer Pump.

